

## Operations Manual for the



### Indoor Model

#### **ALWAYS READ INSTRUCTIONS BEFORE USE**

THIS OPERATIONS MANUAL SHOULD REMAIN WITH THE PERFECT DESCENT AT ALL TIMES AND SHALL ONLY BE REMOVED BY THE END USER. THIS MANUAL CONTAINS INFORMATION ABOUT THE SAFE USE OF THE PERFECT DESCENT CLIMBING SYSTEM AS WELL AS REGISTRATION AND WARRANTY INFORMATION. ENSURE THAT IT IS READILY AVAILABLE TO OPERATORS AT ALL TIMES.

**SERIAL#:** \_\_\_\_\_

Facilities using the Perfect Descent Climbing System should refer to, and abide by the Climbing Wall Association Operations Standards which provides guidelines for the indoor climbing industry, including age restriction, waiver forms, belay checks and climbing facility operating procedures. Also refer to and abide by the Climbing Wall Association's Engineering Standards, the climbing industry standard for load distribution and anchor point placement for artificial climbing walls. Instructions contained herein supersede any information in the aforementioned publications. Both publications are available through the Climbing Wall Association (CWA).

**Climbing Wall Association, Inc.**  
**1460 Lee Hill Rd., Unit 2, Boulder, CO 80304-0870**  
**Phone: 720-838-8284 Fax: 720-528-8200**  
**[www.climbingwallindustry.org](http://www.climbingwallindustry.org)**



**IMPORTANT NOTICE ABOUT SAFETY  
READ BEFORE INSTALLATION AND OPERATION**

**WARNING**

***Climbing is an inherently dangerous activity. Operators of the Perfect Descent Climbing System are responsible for the safety and supervision of climbers using this equipment. C3 Manufacturing requires all operators to be trained before using this product. These instructions must be provided to operators before use of the Perfect Descent Climbing System and retained for reference by operators. Owners and operators must read, understand (or have explained), and heed all instructions, labels, marking, and warnings supplied with this product, and with any associated products intended for use with the Perfect Descent Climbing System. FAILURE TO DO SO MAY RESULT IN SERIOUS INJURY OR DEATH.***

**HEALTH AND SAFETY**

***Owners and operators must abide by all Standards, International, Federal, State and Provincial laws, and any specific health and safety regulations pertaining to the installation and use of this product.***

**SITE PLAN RESCUE**

***Owners and operators must have devised an emergency rescue plan for any climber in distress at all sites operating the Perfect Descent Climbing Systems. Operators must inform users of the Perfect Descent of the procedure for rescuing a climber in distress prior to climbing.***



# TABLE OF CONTENTS

<b>CERTIFICATION .....</b>	<b>7</b>
<b>1.0 - DESCRIPTION OF PERFECT DESCENT CLIMBING SYSTEM.....</b>	<b>8</b>
1.1 - PERFECT DESCENT CLIMBING SYSTEM HOUSING ELEMENTS.....	8
1.2 - PERFECT DESCENT CLIMBING SYSTEM LABELS AND MARKINGS .....	8-9
<b>2.0 - PERFECT DESCENT CLIMBING SYSTEM MODEL 220 SPECIFICATIONS .....</b>	<b>10</b>
<b>3.0 - UNPACKING THE PERFECT DESCENT CLIMBING SYSTEM .....</b>	<b>10</b>
3.1 - PRIOR CONSIDERATIONS.....	10
3.2 - CONTENTS IN PACKAGE.....	10
3.3 - UNPACKING THE PERFECT DESCENT CLIMBING SYSTEM .....	10
3.4 - TRANSPORTATION.....	10
<b>4.0 - INSTALLATION INSTRUCTIONS .....</b>	<b>11</b>
4.1 - PRIOR CONSIDERATIONS .....	11
4.1.1 - MOISTURE.....	11
4.1.2 - PLACEMENT.....	11-12
4.1.3 - HANDLING.....	12
4.2 - ANCHORING THE PERFECT DESCENT CLIMBING SYSTEM USING APPROVED ANCHORAGE HARDWARE.....	12-13
4.2.1 - MOUNTING POINTS.....	13
4.2.2 - EYEBOLT .....	13
4.2.3 - INSTALLATION CARABINER .....	14
4.2.4 - ANCHOR SHACKLE .....	14
4.2.5 - COMPATIBILITY OF ANCHORAGE COMPONENTS .....	14
4.3 - ANCHORING THE PERFECT DESCENT CLIMBING SYSTEM, CUSTOM INSTALLATION.....	14
4.3.1 - UTILIZING UNITS FOR DESCENDING FROM ELEVATED PLATFORMS .....	14
<b>5.0 - TRAINING.....</b>	<b>15</b>
5.1 - USER INSTRUCTION.....	15
<b>6.0 - USAGE LIMITATIONS.....</b>	<b>16</b>
<b>7.0 - HARNESSSES .....</b>	<b>16</b>
<b>8.0 - SUPERVISION DURING USE.....</b>	<b>17</b>

**9.0 - PROPER DESCENDING METHOD ..... 18**

**10.0 - CARABINER OPERATION..... 18**

**11.0 - CARE, MAINTENANCE AND STORAGE ..... 19**

    11.1 - REPLACING THE LINE (AND CARABINER)..... 19

    11.2 - CLEANING INSTRUCTIONS ..... 19

    11.3 - MAINTENANCE AND SERVICE ..... 20

    11.4 - STORAGE ..... 20

    11.5 - SPARE PARTS AND ACCESSORIES ..... 20

**12.0 - LABELS AND MARKINGS..... 21**

**13.0 - PERFECT DESCENT CLIMBING SYSTEM INSPECTION ..... 22**

    13.1 - INSPECTION BEFORE USE..... 22

    13.2 - WEEKLY INSPECTION ..... 22

    13.3 - FORMAL INSPECTION ..... 22

        13.3.1 - FORMAL INSPECTION FREQUENCY ..... 22

        13.3.2 - CONTROL OF EQUIPMENT ..... 23

        13.3.3 - FORMAL INSPECTION PROCEDURE..... 23

            13.3.3.1 - DIAGRAM ..... 23

            13.3.3.2 - FORMAL INSPECTION LOG ..... 23

            13.3.3.3 - FORMAL INSPECTION CHECKLIST ..... 24

            13.3.3.4 - FORMAL INSPECTION PROCEDURAL STEPS, HOUSING..... 24

    13.4 - FORMAL INSPECTION DIAGRAM..... 25

    13.5 - FORMAL INSPECTION LOG..... 26

    13.6 - FORMAL INSPECTION CHECKLIST ..... 27

**14.0 - FACTORY SERVICE..... 28**

    14.1 - FACTORY SERVICE ..... 28

    14.2 - OWNER REGISTRATION ..... 28

    14.3 - WHEN FACTORY SERVICE IS NECESSARY ..... 28

    14.4 - HOW TO OBTAIN FACTORY SERVICE ..... 29

    14.5 - SERVICE AND INSPECTION LOGS..... 30

    14.6 - FACTORY SERVICE LOG..... 30-31

**WARRANTY INFORMATION ..... 33**



## **CERTIFICATION**

- If the Perfect Descent is resold outside of the country of destination, the reseller must provide instructions for use, service, maintenance and repair in the language of the country of use.
- The Perfect Descent can be used as a climbing system device only in combination with other components. It shall not be deemed suitable for use until it is ensured that the entire system complies with the requirements of appropriate regional, state, and federal directives/standards.
- Perfect Descent complies with the following prevailing safety regulations:
  - o AS/NZS 1891: Industrial fall-arrest systems and devices - Part 3: Fall arrest devices
  - o CSA Z259.2.3-99: Descent control devices
  - o EN 341: 1992 + A1: 1997 Class A: Personal protection equipment against falls from height-descender devices
  - o ANSI/ASSE Z359.4: Safety requirements for assisted-rescue and self rescue systems, subsystems and components

## 1.0 DESCRIPTION OF PERFECT DESCENT CLIMBING SYSTEM

The Perfect Descent Climbing System is a controlled descent device for recreational climbing, and is used in indoor climbing gyms, on portable climbing walls, or challenge courses. It is installed where a top-rope would be, thus eliminating the need for a belayer by providing a hands free belay for the climber. Once the climber lets go of the wall, however, the climber cannot hang suspended by the Perfect Descent Climbing System, and will automatically be lowered to the ground at a continuous, controlled rate. The line automatically retracts into the unit, permitting repeated descents. The Perfect Descent Climbing System is NOT designed for lead climbing.

### 1.1 PERFECT DESCENT CLIMBING SYSTEM HOUSING ELEMENTS

- **INSTALLATION HANDLE**
  - Connection point for anchoring the Perfect Descent Climbing System to the climbing structure. Also serves as a carrying handle. Anchoring elements should always secure through the installation handle.
- **BRAKE HOUSING**
  - The metal housing that contains the brake mechanism.
- **TAMPER RESISTANT BOLTS**
  - Provides evidence that the system has been tampered with by other than an authorized factory representative. **NEVER** open the housing or attempt a field repair. Serious injury could result.
- **NOZZLE**
  - Helps seal the unit, prevent contaminants from entering the housing, and prevents line twisting.
- **LINE**
  - 1" nylon wear indicating webbing. This is a yellow lanyard with a black wear indicator on each side. Should the lanyard wear though on any indicator, it must be replaced.
- **SWIVEL CARABINER**
  - Provides a self-locking attachment means to the climber's harness.

### 1.2 PERFECT DESCENT CLIMBING SYSTEM LABELS AND MARKINGS

- **FACE LABEL**
  - Displays product logo.
- **BACK LABEL**
  - Explains inspection before use and installation instructions. Reading the back label is not a substitute for reading and understanding these Operator Instructions.
- **SERVICE DATE LABEL**
  - Completed by the manufacturer. Provides information vital to the inspection and factory service procedures explained in Section 14. This label is located on the side of the unit.
- **SPECIFICATION LABEL**
  - Contains model specific information.



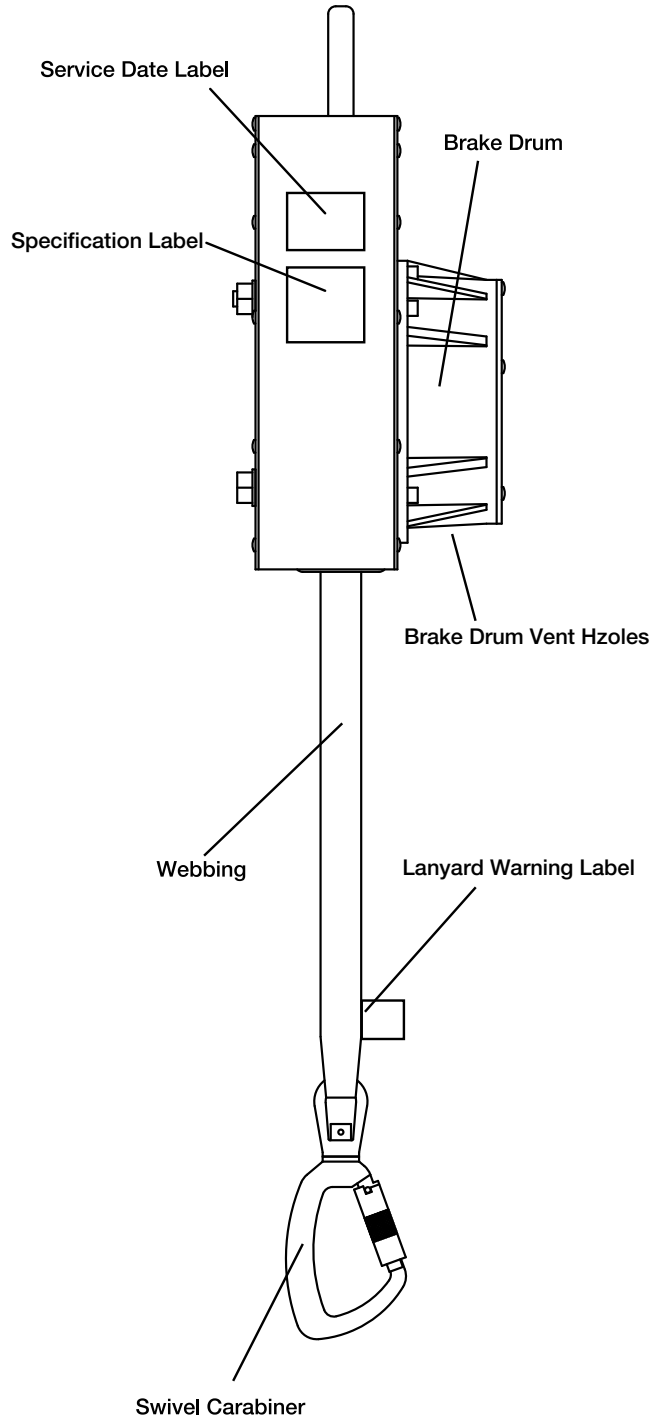
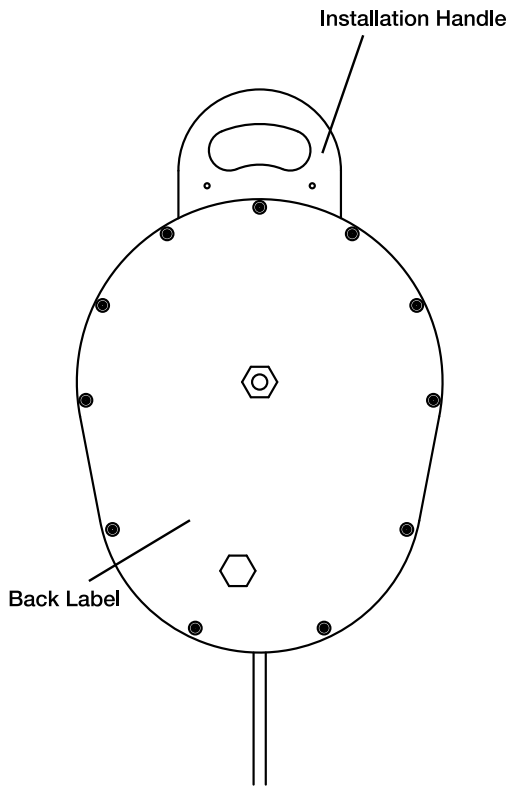
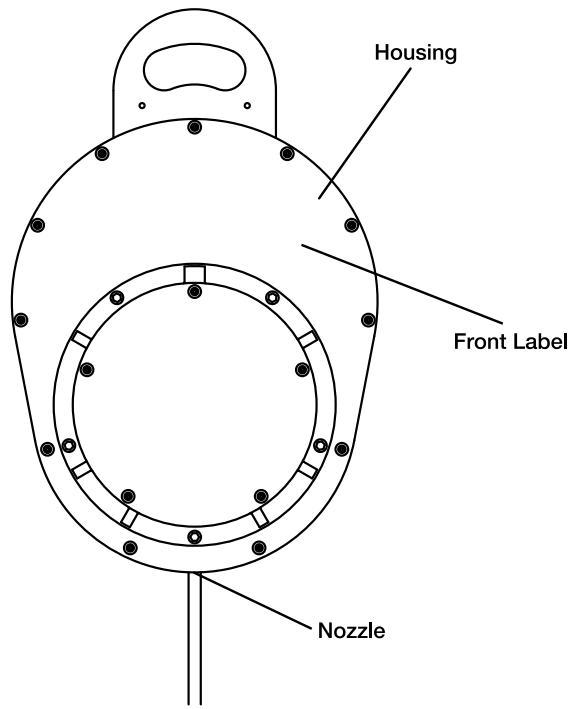

## 2.0 PERFECT DESCENT CLIMBING SYSTEM SPECIFICATIONS, INDOOR

- Line specs: 28, 40, or 52ft. (8.5, 12.2, or 15.9m) long, comprised of 1" Nylon/ Spectra Webbing
- Case Dimensions: 16x9.5x7.5 in (40x24x19 cm)
- Net Weight: 28.5-30 lbs (13-13.6kg)
- Decent rate:
  - o Maximum: 6.6 ft/s (2m/s)
  - o Minimum: 2.3 ft/s (0.7m/s)
- Retraction Rate: ~ 2.5 ft/s (0.75m/s)
- Maximum weight of climber: 310 lbs (140 kg)
- Minimum weight of climber: 25 lbs (16 kg)
- Materials
  - o Casing: stainless steel and aluminum
  - o Line: minimum breaking strength 3,500 lbs (15.6 kN) when new
  - o Internal parts: stainless steel and/or aluminum

## 3.0 UNPACKING THE PERFECT DESCENT CLIMBING SYSTEM

### 3.1 PRIOR CONSIDERATIONS

- Ensure that this operations manual is readily available to Perfect Descent users at all times. It contains information relating to the safe use of the Perfect Descent Climbing System and includes all product registration and warranty information. It may only be removed by the end user.
- DO NOT DISPOSE OF THE PACKAGING
  - o The cardboard box and internal packing materials will be required for the return of the unit every two years for inspection. Please keep the packaging in a safe, dry place until required.

### 3.2 CONTENTS IN PACKAGE

- The Perfect Descent Climbing System is packaged in a cardboard box and contains:
  - o 1 Perfect Descent Climbing System
  - o 1 Lanyard, either 28, 40, or 52 feet (8.5, 12.2, or 15.9m)
  - o 1 Carabiner
  - o 1 Operations Manual
  - o 1 Warranty Registration Card

### 3.3 UNPACKING THE PERFECT DESCENT CLIMBING SYSTEM

- Upon receipt of the unit, first inspect the box for signs of shipping damage. If there appears to be damage, contact your Perfect Descent distributor.
- Check to see that all labels are affixed to the Perfect Descent and legible.
- Check the Certification Label for the "Next Service Due." If the date shown has passed or the label is missing or illegible, the Perfect Descent must not be put into service.
- Fill out the Owner Registration Card and return it for product registration.
- Read the Operations Manual and familiarize yourself with all aspects of installation, operation, care and maintenance.

### 3.4 TRANSPORTATION

- If the Perfect Descent is to be returned to C3 Manufacturing or an authorized service center for servicing please return it in the original packaging. Repackage Perfect Descent as shown:

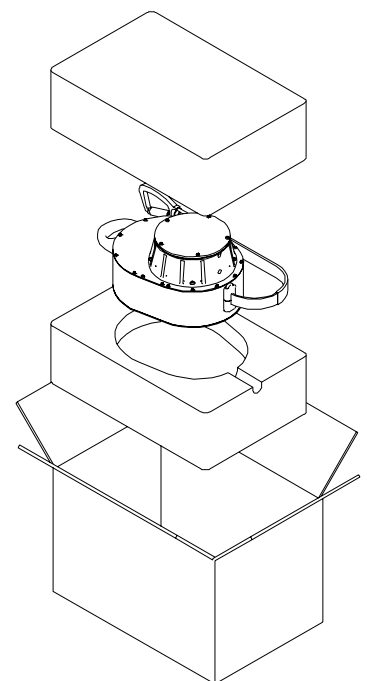

## 4.0 INSTALLATION INSTRUCTIONS

### 4.1 PRIOR CONSIDERATIONS

#### 4.1.1 MOISTURE

- If moisture is allowed to remain in contact with the internal mechanism, the effectiveness of the braking system as well as the useful life of the Perfect Descent Climbing System may be reduced. The Perfect Descent Climbing System has one opening where water can enter the internal mechanism: the nozzle. When the Perfect Descent Climbing System is installed correctly with the nozzle facing straight down, moisture will flow primarily over the protective housing, or drain out through the nozzle opening. It is important that the Perfect Descent Climbing System is installed in an upright position. **DO NOT MOUNT THE PERFECT DESCENT CLIMBING SYSTEM HORIZONTALLY.** Mounting the device horizontally will permit moisture and brake dust to accumulate inside the brake housing. Prolonged exposure to moisture will cause corrosion to the brake mechanism and can contribute to mechanical malfunction such as difficulty in retracting or extracting line.

#### **WARNING**

*Ensure that the brake mechanism is dry prior to operation. If the brake mechanism remains wet a climber may experience an increased rate of descent, or jerky descent.*

- When transporting or storing the Perfect Descent Climbing System on a portable rock wall, always remove the device, or cover it with a waterproof cover to prevent water damage. This is especially important if the device will be transported or stored in a horizontal position, where water or road salts can enter and remain trapped inside the mechanism for extended periods. A protective cover can be created from a plastic bag or tarpaulin, as long as the cover prevents water from entering and remaining inside the Perfect Descent Climbing System. Remove or cover the unit whenever the rock wall is laid horizontally. Do not lay the Perfect Descent Climbing System down where water can enter and remain inside the unit.

#### 4.1.2 PLACEMENT

- Install the Perfect Descent Climbing System with sufficient clearance to permit freedom for the device to rotate several inches back-and-forth and side-to-side. **DO NOT** rigidly mount the Perfect Descent Climbing System to the climbing wall, as this can result in premature wear of the line.

#### **WARNING**

***DO NOT rigidly mount the Perfect Descent Climbing System to the climbing wall.***

- Install the Perfect Descent Climbing System over the intended descent path with the housing oriented vertically and line nozzle facing down. Install where the line can hang unobstructed by the climbing wall or climbing holds. Do not allow the line to pass over sharp edges or drag on the wall or hand holds during descent. Always avoid installation where the line can become lodged behind hand holds or other obstructions. Mount the Perfect Descent Climbing System so as to prevent a climber from climbing above the unit.

Install the unit overhead to minimize swing hazards, and to prevent excessive wear on the nozzle. Ensure that the height of the wall does not exceed the line length of the lanyard; either 28, 40, or 52 ft. (8.5, 12.2, or 15.9m) depending on which lanyard is in the unit. Also ensure that climbers cannot forcibly extract the line beyond this length to its termination point. If installation is on a portable climbing wall, secure the unit where it is easily accessed for inspection and removal prior to transport.

- Consider all possible paths of climber movement and all factors that could affect climber safety while climbing and descending, anywhere along these paths. Consider the location of the entire length of line as the prospective climber moves around. It should not pass over, under or around the path of another climber. Never install the Perfect Descent Climbing System where the housing or line can encounter electrical hazards.
- Always mount the Perfect Descent with the Back Label facing the wall and the Brake Drum facing away from the wall.

### **4.1.3 HANDLING**

- Take care when lifting the Perfect Descent Climbing System as it is a heavy item: 30 lbs (13.6 kg).
- Take precautions to avoid dropping the Perfect Descent Climbing System when it has been detached from the climbing wall. Damage can occur if the Perfect Descent Climbing System is dropped. This damage may not be evident upon inspection of the external housing, and may result in interference with normal line retraction. If you suspect that a Perfect Descent Climbing System has been dropped, resulting in damage to the internal mechanisms, remove the unit from use and immediately return to C3 Manufacturing or an authorized service center for service.
- When not in use, the line of the Perfect Descent Climbing System should be retracted completely into the housing. This will prolong the life of the retraction spring. When not in use, a tag line can be connected to the carabiner for retrieving and returning the line into the housing. While in use, it is recommended to keep the carabiner clipped to an eyebolt or hanger at the base of the climb, where it is available to the operator.
- Never release the line, allowing it to re-reel back into the Perfect Descent Climbing System in an uncontrolled manner.

## **4.2 ANCHORING THE PERFECT DESCENT CLIMBING SYSTEM USING APPROVED ANCHORAGE HARDWARE**

- The Perfect Descent Climbing System must be linked to an anchorage so as to prevent accidental disengagement or rollout. There are many elements of installation hardware that are suitable for installation. The information that follows discusses a few that are in general use and readily available. Most installations can be accomplished using these hardware elements individually or combined as described. All installation methods and hardware must meet the minimum requirements set forth by these instructions. Never use installation methods and hardware other than those recommended by C3 Manufacturing unless such other hardware and methods have been recommended to be suitable by C3 Manufacturing, or approved by a qualified engineer. All installation hardware and the mounting location on the climbing structure must meet a minimum strength requirement of 4,400 lbs (19.6 kN) in the direction of anticipated loading.
- All anchor points and connectors used with the Perfect Descent must conform to any federal or state requirements for such devices.
- Minimum requirements for anchor points must conform to the requirements of EN 12572: Climbing

wall anchor points, and EN 795: Anchor Devices.

- The location and anchor points for the Perfect Descent should comply with the following:
  - o Minimum load capacity of the anchor point(s) of 4,400lbs (19.6 kN) in expected directions of application.
  - o Anchor points are not to be used by other devices or as attachments for hardware not associated with the Perfect Descent installation.
  - o Anchor points should be a suitable size to correctly install any mounting hardware.
- All secondary connectors and hardware used in the installation of the Perfect Descent must conform to the requirements of EN 362: Types of connectors for personal protection, and EN 12275- Types of connectors for mountaineering.

#### 4.2.1 MOUNTING POINTS

- The only place the Perfect Descent is to be mounted from is the handle. It can either be mounted with a single or double point mounting.
  - o For single point mounting, only one connection point is connected to the handle as shown below.
  - o For double point mounting, two connection points are connected to the handle, one on either side as shown below.

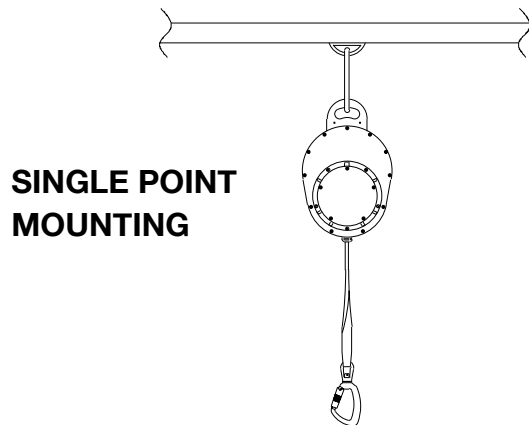

**SINGLE POINT MOUNTING**

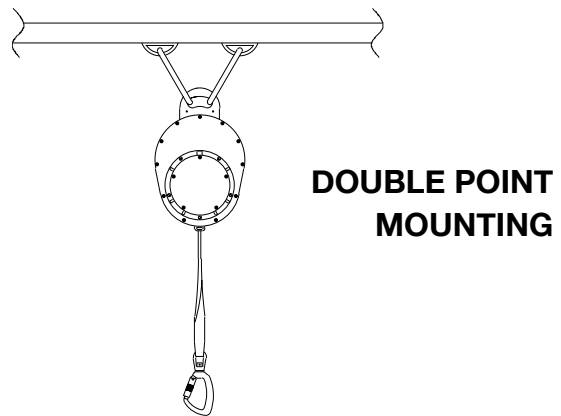

**DOUBLE POINT MOUNTING**

#### 4.2.2 EYEBOLT

- Eyebolts must be of weld-less forged alloy steel construction with a shoulder pattern, threaded shank, washer and nut. The length of shank and diameter of the threaded cross-section shall be appropriate for the specific installation. The breaking strength must be a minimum 4,400 lbs (19.6 kN) for any loading direction anticipated by the system. Verify that intermediate anchorage connectors (carabiner or shackle) are compatible to prevent accidental disengagement (“rollout”). Proper selection and installation must be performed under the supervision of a qualified person. Always install the eyebolt such that the anticipated loading direction is within 30° of the eyebolt axis. Never install to an eyebolt mounted horizontally. Eyebolts without a nut are not recommended because they can work loose. Verify that the nut is properly torqued against the washer and will not loosen over time, and that the structure to

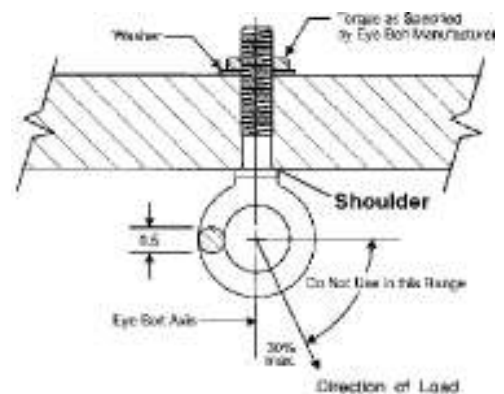

which the eyebolt is mounted is capable of supporting 4,400lbs (19.6 kN) in the direction of anticipated loading.

#### 4.2.3 INSTALLATION CARABINER

- Two locking steel carabiners can be used as an anchorage connector when linked between the Perfect Descent Climbing System Installation Handle and an appropriate anchorage connector. While one carabiner is sufficient, two is recommended to spread load and reduce wear on the handle. Each carabiner must have a minimum breaking strength of 5,000 lbs. Always verify that the carabiners are loaded along their major axis, with the gate closed and locked. Loading the carabiners in any other manner will reduce their strength to the point where it may fail.

#### 4.2.4 ANCHOR SHACKLE

- A bolt-type anchor shackle that is of weld-less forged alloy steel construction may be used as a link between the Perfect Descent Climbing System Installation Handle and an appropriate anchorage connector. Shackles should comply with U.S. Federal Specification RR-271. These are referred to as safety anchor shackles because the shackle bolt is secured with a nut and a cotter pin to reduce the possibility of the bolt coming out. It is recommended that the shackle with a nominal 0.5 inches be used. Never replace an original shackle bolt with a regular bolt. Never use the shackle without the nut and cotter pin in place. The Perfect Descent Climbing System installation handle should bear on the shackle bow.

DIMENSIONS		
	IN.	CM.
A	1.2	3.1
B	0.8	2.1
C	0.5	1.3
D	1.9	5.0
E	0.6	1.6

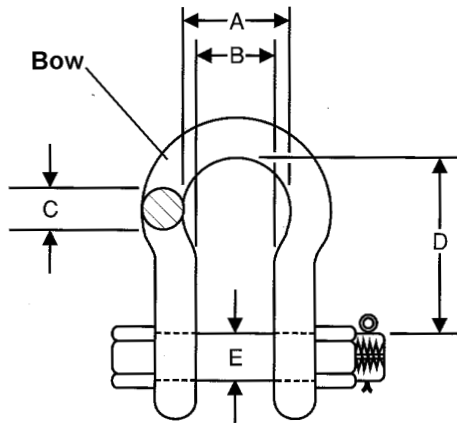

Weldless forged alloy steel.  
Nut and cotter pin must be securely in place.  
Min. Breaking strength = 14,000 lbs. (62.3 kN).

#### 4.2.5 COMPATIBILITY OF ANCHORAGE COMPONENTS

- Connecting hardware must be compatible in size, shape, and strength. Non-compatible connectors may accidentally disengage (“rollout”). Always verify that connection elements of the anchorage are compatible.

#### 4.3 ANCHORING THE PERFECT DESCENT CLIMBING SYSTEM, CUSTOM INSTALLATION

- It is possible to design and fabricate a custom means of installation. Installation must meet the minimum anchorage strength requirements of 4,400 lbs (19.6 kN) in the direction of anticipated loading. When designing a custom installation, consider and eliminate any potential obstructions that could compromise the proper function and line extraction of the Perfect Descent Climbing System. C3 Manufacturing does not recommend that the line pass over a pulley or sheave, so as to orient the housing off of vertical. All custom installations must be designed or approved by a qualified engineer. Mount the Perfect Descent Climbing System in a manner that ensures that it will not work loose. Always anchor the Perfect Descent Climbing System through the Installation Handle.

#### 4.3.1 UTILIZING UNITS FOR DESCENDING FROM ELEVATED PLATFORMS

- Mount your unit so that the attachment carabiner hangs 6 feet above the height of the platform floor. Mount the unit at a distance 20” - 24” protruding from the platform. Ensure the descent path and landing

area are free of people and obstructions.

## 5.0 TRAINING

It is the responsibility of the purchaser of the Perfect Descent Climbing System to assure that operators read and understand these operator instructions, and are trained in:

- How to properly inspect, use, transport, store and maintain the Perfect Descent Climbing System.
- How to properly install the Perfect Descent Climbing System.
- Proper attachment locations and methods, including compatibility of connections to eliminate the possibility of accidental disengagement.
- The consequences of improper use of the Perfect Descent Climbing System and associated equipment, and of failure to follow instructions and training.
- How to instruct climbers on the proper use of the Perfect Descent Climbing System.
- How to supervise climbers using the Perfect Descent Climbing System.

It is the responsibility of all operators of the Perfect Descent Climbing System to ensure that all users (climbers) are:

- Properly fit and secure in a manufactured climbing harness.
- Properly attached by the Perfect Descent Climbing System carabiner to their climbing harness.
- Instructed on proper techniques for ascending and descending using the Perfect Descent Climbing System.
- Instructed on what to do in the event that a slack line condition, or improper retraction rate is observed while climbing.

## 5.1 USER INSTRUCTION

- Prior to clipping in, all climbers must be instructed in the safe use of the Perfect Descent. Operators are to insure that all climbers are familiar with the site rescue plan in the event the climber becomes distressed. Climbing is considered a strenuous activity. If you have any physical or medical condition that may affect your climbing ability, consult a medical professional prior to participation.
- Ensure the carabiner is attached to the climbing harness per manufacturer's recommendation and the latch is fully closed and the gate engaged before starting to climb. **FAILURE TO DO SO CAN RESULT IN SERIOUS INJURY OR DEATH.**
- Prior to climbing, the user must be aware of, and completely understand the following precautions:
  - o Check Perfect Descent by pulling out a short section and allowing it to retract.
  - o In the Perfect Descent line fails to retract during climbing, stop climbing immediately and request assistance.
  - o Check the climbing harness is correctly fitted and tightened.
  - o Check the carabiner from the Perfect Descent lanyard is connected to the designated attachment point on the climbing harness and the gate is properly closed.
  - o Ensure the carabiner latch gate is facing away from the climber.
  - o Never climb alongside or above the Perfect Descent.
  - o Never start descent from above the Perfect Descent.
  - o Prior to descent, ensure descent path and landing area are free of people and obstructions.
  - o Always descent feet first using feet to fend off obstacles and prepare for landing.

## 6.0 USAGE LIMITATIONS

- The Perfect Descent Climbing System is designed for use by one person at a time. The designed weight range is between 35 lbs and 310 lbs (16 and 140 kg). Persons with muscular, skeletal, or other physical disorders should consult a physician before using the Perfect Descent Climbing System. Consult a physician if there is any question about physical ability to safely climb or use this product.
- Do not expose the Perfect Descent Climbing System to environments with prolonged temperatures greater than 185°F (85°C). Do not expose the Perfect Descent Climbing System to a corrosive environment. Always remove or seal the unit during trailer transport. The Perfect Descent Climbing System internal parts should be protected from foreign materials, moisture and water. Do not install where the unit or line can come in contact with an electrical source. Any Perfect Descent Climbing System that shows signs of excessive wear, deterioration, malfunction, or insufficient retraction force must be removed from use, marked as “Unusable” and returned to a C3 Manufacturing approved service center for repair. (See section 13 for detailed inspection procedure, and section 14 for factory service information.)

## 7.0 HARNESES

- All harnesses used in conjunction with the Perfect Descent Climbing System must comply with the following standards:
  - EN 361 – Personal protective equipment for prevention of falls from a height – Full body harness
  - EN 813 – Personal protective equipment for prevention of falls from a height- Sit harness
  - EN 12277 – Type A Full Body Harness
  - EN 12277 – Type B Small Full Body Harness
  - EN 12277 – Type C Sit Harness
- C3 Manufacturing recommends that climbers be equipped with a full body climbing harness, with a means of connecting to the Perfect Descent Climbing System at the chest. Use of a full body harness will minimize the chances of an inverted fall. Children under the age 10 must always be equipped with a full body climbing harness. Follow manufacturer’s recommendations for fitting, attachment and proper threading of buckles. The Perfect Descent Climbing System carabiner should be attached to the climbing harness as per the manufacturer’s instructions. Operators should always check for proper harness fit and attachment to the Perfect Descent Climbing System carabiner prior to climber ascent. Refer to the manufacturer’s instructions and the Climbing Wall Association’s website for information on the design, use, maintenance and limitations of climbing harnesses.



## 8.0 SUPERVISION DURING USE

- Training provided by the operator to users (climbers) of the Perfect Descent Climbing System should include, as a minimum, those areas outlined in section 5.0.
- Climbers should be under constant supervision by a trained operator. Before ascending the wall, operators should check to verify that each climber has:
  - Properly fit and secured climbing harness.
  - Properly clipped their harness onto the Perfect Descent Climbing System carabiner.
- Once the climber's harness is attached, always check that the gate on the carabiner is locked and secure by depressing the gate.
- Operators should provide instructions regarding proper technique for ascending and descending the wall while using the Perfect Descent Climbing System.
- Do not allow climbers to ascend above the Perfect Descent Climbing System, or climb off route or in the path of another climber.
- Climbers should be prevented from climbing on an area of the wall that would produce a swinging fall.
- Always maintain a safe, unobstructed landing area that is free of objects and other climbers.
- Discourage climbers from releasing the line, allowing it to re-reel back into unit in an uncontrolled manner.
- Do not allow climbers to loop the line around holds, or secure the line through quickdraws in order to redirect descent.
- Do not allow the line to become wrapped around the arms, legs or neck.

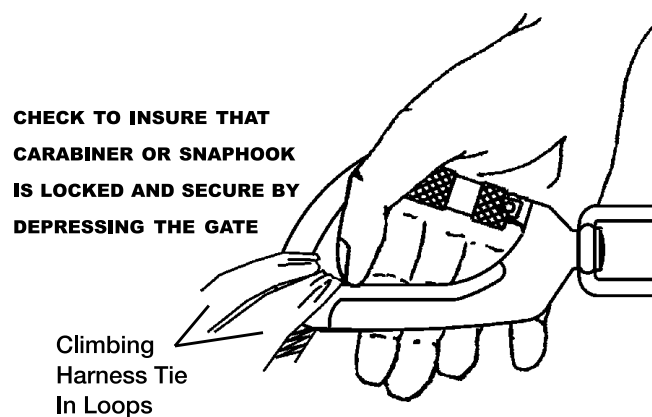

- Operators should warn climbers not to allow a slack line to develop. A slack line resulting in free-fall could seriously injure a climber or break the line. Instruct the climber that in the event of a slack line, he or she should remain stationary on the wall, and notify the operator immediately. If a climber has ascended without recognizing the slack line, the climber should be instructed to remain in place on the wall. Rescue the climber by attaching their harness to a secondary lowering system, (top rope or second Perfect Descent Climbing System) and lowering them to the ground. Always ensure that this rescue system is available and in place, and that all operators have been trained on a rescue procedure.

## 9.0 PROPER DESCENDING METHOD

- When descending, the climber should let go of the climbing wall, transferring their weight to the Perfect Descent Climbing System. The climber will feel little tension on the line until he/she has begun the descent. The climber should sit back in their harness and walk their feet down the wall. Always provide a safe, unobstructed landing surface.
- If a climber is anxious or unfamiliar with the function of the Perfect Descent Climbing System, it is recommended that the climber ascend a short distance and descend in order to become acquainted with the device.

## 10.0 CARABINER OPERATION

- The carabiner provided with Perfect Descent Climbing System is either a two stage or three stage self-closing and self locking carabiner.
- The **Two Stage Carabiner** is opened by first twisting the knurled gate collar 90° and then depressing the gate.

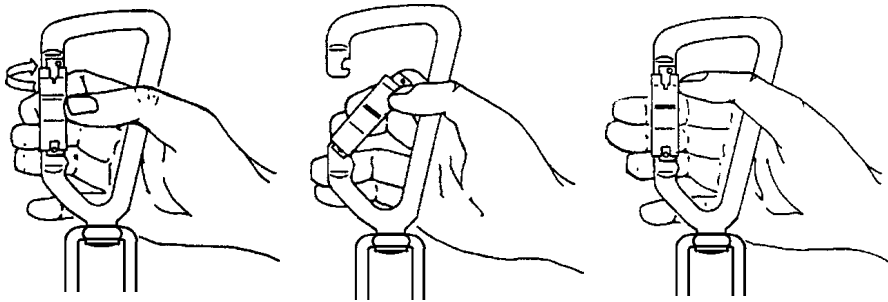

a) Rotate collar 90 degrees about its axis

b) Depress collar until it pivots about the hinge

c) Release gate and it should automatically close and lock

- The **Three Stage Carabiner** is opened by first lifting the collar until it stops, then twisting the knurled gate collar 90°, and then depressing the gate.

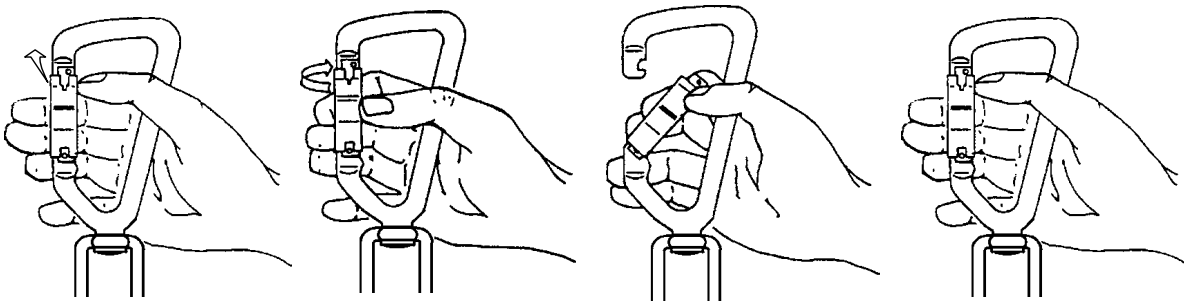

a) Lift the collar until it stops

b) Rotate collar 90 degrees about its axis

c) Depress collar until it pivots about the hinge

d) Release gate and it should automatically close and lock

- When attaching the carabiner to a harness, verify that the harness webbing or clothing is not obstructing closure of the gate. Always check the gate after attaching to the manufacturer recommended harness attachment point(s) by depressing the gate to verify that it is fully closed and locked.

### **WARNING**

*Double check to make sure the carabiner gate has properly closed and latched prior to use.*

## 11.0 CARE, MAINTENANCE AND STORAGE

- Inspect the Perfect Descent Climbing System by following the guidelines laid out in section 13 of this manual.
- The useful life of the Perfect Descent Climbing System is dependent upon the operator's proper care of the unit, including maintenance and storage. If the Perfect Descent Climbing System is used on a portable climbing wall, always remove the Perfect Descent Climbing System, or seal the unit from water, salt, and contaminants before transport. Factory service is required every two years to keep the product in good working condition and ensure its integrity. Proper care and maintenance of the product by the operator is essential during the two year intervals between factory servicing.
  - Prevent denting or deformation of the housing. Never drop the unit from any height, and always set it down carefully.
  - When in use, protect the line from contacting sharp corners and edges.
  - DO NOT allow foreign matter to enter the housing.
  - Heed all caution labels and instructions as these are intended to prevent damage to the product as well as guide the operator in correctly operating the Perfect Descent Climbing System.
- **DO NOT STORE IN A WET CONDITION**
  - After exposure to water or damp conditions, thoroughly clean and dry the Perfect Descent. Ensure that the unit is not left with wet webbing line retracted inside the casing. Always store the unit in a clean, dry environment.

### 11.1 REPLACING THE LINE (AND CARABINER)

- The Perfect Descent Climbing System comes equipped with a line that may be replaced in the field by the owner/operator. If a line appears damaged, excessively fuzzy, worn, sun bleached, or if the wear indicators have begun to fray, it should be replaced immediately. Replace the line as part of the regular maintenance schedule. Always keep a replacement line and the appropriate tools on hand in the event that a line requires immediate replacement. Frequency of replacement will vary depending upon use. Line replacement kits can be ordered from can be purchased from an authorized dealer or service center. Full instruction for the line replacement is included with the line replacement kit.

### 11.2 CLEANING INSTRUCTIONS

- To clean the housing, use a clean, damp (not wet) cloth to remove dirt or contamination which may cause corrosion or hamper readability of labels. Wipe off any moisture before returning the Perfect Descent Climbing System to service. The frequency of cleaning should be determined by inspection and by severity of the environment. In highly corrosive environments, cleaning will be required more often. Never use solvents to clean the housing as they may break down the label adhesive. DO NOT use abrasives to scour the housing as they may damage the plating and the labels. Never immerse the product in water or other liquid. If water gets into the housing, hang the device and slowly extract the entire lifeline allowing the water to run out of the lifeline orifice. Use a clean dry cloth to wipe the line dry as it is slowly re-reeled back into the device. Leave the device hanging in a warm dry room with the line extracted. Questions concerning Perfect Descent Climbing System condition and cleaning should be directed to C3 Manufacturing.

### **11.3 MAINTENANCE AND SERVICE**

- Major maintenance can only be performed at the factory, but the routine maintenance, specified herein is permissible for the operator to perform. Proper maintenance is both preventive and corrective in nature.
- Proper maintenance of the Perfect Descent Climbing System includes regular cleaning unit housing to remove dust and chalk. A Perfect Descent Climbing System that is under continual use should be cleaned weekly.
- Proper maintenance of the carabiner includes cleaning and lubricating the gate hinge, swivel and locking collar with a cleaning lubricant, such as WD-40. Spray the carabiner with lubricant between all moving parts, and activate the locking gate and swivel several times to assist lubricant penetration. DO NOT allow lubricant to contact the nylon line as this may weaken the line. Wipe off any excess lubricant and allow to dry. If the gate is ever observed to stick open or unlocked during use, take the Perfect Descent Climbing System out of service immediately until it is properly lubricated and it is verified that the connector will close and lock automatically. If lubrication does not correct the problem, immediately remove the Perfect Descent Climbing System from use until the line has been replaced with a Line Replacement Kit.
- Equipment which is damaged or in need of maintenance must be tagged as “UNUSABLE” and removed from service. Corrective maintenance (other than cleaning) and repair, such as replacement of elements, (other than the line with integral nozzle and attachment element), must be performed only by C3 Manufacturing or an authorized service center. Do not attempt field repairs.

### **11.4 STORAGE**

- Store the Perfect Descent Climbing System in a cool, dry and clean place. Avoid areas where heat, moisture, oil and chemicals or their vapors or other degrading elements may be present. Heavily soiled, wet, or otherwise contaminated equipment should be properly maintained (e.g. dried and cleaned) prior to storage. Ensure that the exterior line does not come in contact with grease, oils, gas, or other chemicals that may weaken it.
- Never allow the Perfect Descent Climbing System to rest for lengthy periods of time on concrete or ash floors as the lime sulfur and ash can cause corrosion. Store the device with the lifeline fully retracted. Prior to using equipment which has been stored for long periods of time, a Formal Inspection should be performed by a competent person.

### **11.5 SPARE PARTS AND ACCESSORIES**

- Your Perfect Descent is fitted with a number of user replaceable parts that may be refitted without the need to return the device to an authorized service center. Always follow the instructions as detailed in the User Manual and any Part Replacement Guide supplied with undertaking the replacement of a part.
- Replacement parts that can be ordered include:
  - o Lanyard replacement kit
  - o Nozzle replacement kit

# 12.0 LABELS AND MARKINGS

- The following labels must be present, legible and securely attached to the Perfect Descent Climbing System. If not, remove the Perfect Descent Climbing System from use and mark it as “UNUSABLE” until a Formal Inspection is performed.

Front Label

Back Label

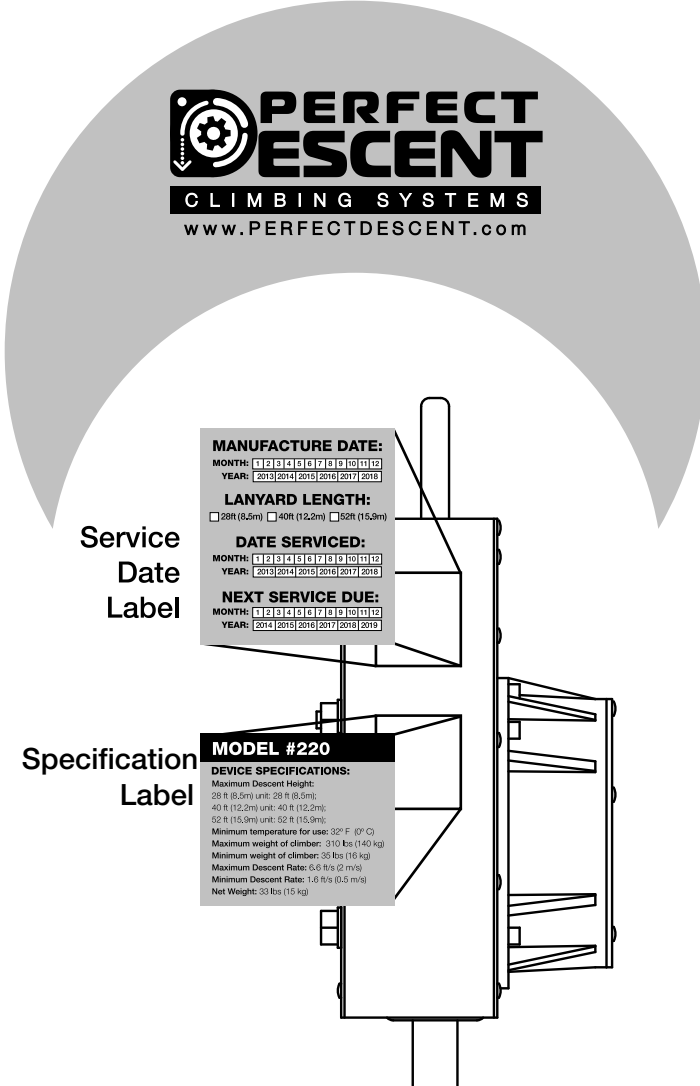

## **13.0 PERFECT DESCENT CLIMBING SYSTEM INSPECTION**

### **13.1 INSPECTION BEFORE USE**

- The Perfect Descent Climbing System should be inspected before each use to verify that the unit is functioning properly. Check, by pulling on the line, for resistance produced by the braking mechanism. Verify smooth, even deployment of the line. Return the line back into the housing in a controlled manner and verify adequate and smooth retraction force. If inspection reveals improper function, or any abnormality remove the Perfect Descent Climbing System from use immediately and submit for factory service. Do not use the Perfect Descent Climbing System if inspection reveals an unsafe condition.

### **13.2 WEEKLY INSPECTION**

- While the Perfect Descent Climbing System is in use, a thorough inspection should be performed on a weekly basis. Inspect the sewn stitching at the end of the line for broken, frayed, or missing threads. Inspect the line along its entire length, checking for excessive wear, burns, cuts, sun bleaching, chemical or other damage. Also make sure the wear indicators are not worn through or frayed. If any of these conditions exists, remove the unit from use until the line can be replaced. Examine the function of the Perfect Descent Climbing System as specified in section 13.1. Examine the line termination near the carabiner, paying particularly close attention to the first few feet of line for damage. Check that the carabiner functions properly, and automatically closes and locks when released. Follow the procedures in Section 10 if a carabiner fails to close or lock automatically.
- Check all fasteners on the housing to be sure that they are tight. Check that none of the hardware or fasteners are missing, damaged, or has been improperly substituted or altered in any way. Check that the housing is not damaged or dented, and that the installation handle is not worn or damaged. Check all metallic parts, including the carabiner and installation hardware, for deformation, fractures, cracks, corrosion, cuts, deep nicks, and evidence of excessive heat or chemical exposure. Check for excessive wear on the installation handle and nozzle. Check the anchorage hardware for excessive wear, loose or missing components, or damage. If any of these conditions exist, remove from use and submit to factory service according to Section 14. Do not use the Perfect Descent Climbing System if inspection reveals an unsafe condition.

### **13.3 FORMAL INSPECTION**

#### **13.3.1 FORMAL INSPECTION FREQUENCY**

- The Perfect Descent Climbing System must be formally inspected by a competent person at intervals of no more than six months. If the Perfect Descent Climbing System is exposed to severe conditions, more frequent formal inspections may be required. The frequency of inspection should be established by the operator's organization based on such factors as the nature and severity of conditions, frequency of use, and exposure time of the equipment. The inspector should perform a methodical and thorough visual and tactile inspection by following the inspection procedure in section 13.3.3. The inspection results should be recorded in the Formal Inspection Log and retained for reference.

### **13.3.2 CONTROL OF EQUIPMENT**

- The operator's organization should establish and enforce a policy and procedure whereby any Perfect Descent Climbing System that is found to be defective, damaged, or in need of maintenance be immediately removed from use, marked as "UNUSABLE" and immediately submitted to custody of the person responsible for Formal Inspection. This has the benefits that:
  - 1) defective equipment is secured from further use until proper action is taken;
  - 2) uniform standards are applied for determining whether the equipment is acceptable or not acceptable for further use;
  - 3) uniform methods of cleaning, line and carabiner replacement and other maintenance are applied;
  - 4) there is a central point for evaluation of conditions that may be recurring and require preventive measures such as coordination with the equipment manufacturer, selection of alternate equipment, additional training of equipment users, or changes to the conditions of use.

### **13.3.3 FORMAL INSPECTION PROCEDURE**

- The Formal Inspection Procedure is similar to the weekly inspection described in section 13.2. However, it differs in three important respects:
  - 1) it is performed by a person who is trained and authorized to perform Formal Inspection
  - 2) it is more detailed and is methodically recorded on a Formal Inspection Log that is kept on file for future reference
  - 3) it results in final disposition of the equipment as either "acceptable" or as "not acceptable" followed by factory service of the product.
- The described detailed inspection record keeping is needed in order to trace detected defects to their causes. A simplified alternative procedure is also explained below.
- There are three forms that are important to the Formal Inspection Procedure. They are the Formal Inspection Diagram ("DIAGRAM"), the Formal Inspection Log ("LOG"), and the Formal Inspection Checklist ("CHECKLIST"). These forms relate and refer to each other so it is necessary to understand their purposes and uses before discussing the inspection procedure.

#### **13.3.3.1 DIAGRAM**

- This is a drawing of the Perfect Descent Climbing System with numbers corresponding to those on the Formal Inspection Log in the column titled "Inspection Number." (See section 13.4)

#### **13.3.3.2 FORMAL INSPECTION LOG**

- This form is to be used to record observations made during the Formal Inspection (See section 13.5). The "Model Number," and "Manufacture Date" may be found on the side labels. The "serial Number" is stamped into the metal faceplate below the Brake Drum. The "Inspector," "Inspection Date," and "Condition of Unit" are to be entered upon inspection by the inspector. The Condition of the Unit is to be termed either "Acceptable" or "Not Acceptable."
- The columns on the LOG are as follows:
  - o Inspection number: These numbers correlate to the numbers on the DIAGRAM.
  - o Description: This is the name of the Perfect Descent Climbing System inspection point. There are five categories for inspection: Lanyard, Carabiner, Casing/Brake Housing, Handle and Function.
  - o QTY: Quantity per Perfect Descent Climbing System. The quantity of each Perfect Descent Climbing System inspection point that must be inspected
  - o Comments: This is where the inspector indicates their observations.
  - o Pass/Fail: This is where the overall condition of the Perfect Descent Climbing System is to be noted. If any defective conditions are observed with the Perfect Descent Climbing System, the inspector is to note "Fail" in this column. If no defective conditions exist, note "Pass."

### 13.3.3.3 FORMAL INSPECTION CHECKLIST

- This table categorizes the different types of Perfect Descent Climbing System parts into five categories: Lanyard, Carabiner, Casing, Brake Housing, and Handle (See section 13.6). For each of these categories, the formal inspector checks the Perfect Descent Climbing System parts for each of the associated conditions (e.g. deformed, fractured, missing, loose, etc.). Any condition observed is to be noted in the “Overall Results” column, any concerns discussed in the “Comments” column, and then a pass or fail noted in the “Pass/Fail” column.

### 13.3.3.4 FORMAL INSPECTION PROCEDURAL STEPS, HOUSING

- **Step 1:** Record on the LOG the Model Number, Serial Number and Manufacture Date information shown on the service and date label. Record the inspector’s name and inspection date.
- **Step 2:** Suspend the Perfect Descent Climbing System oriented vertically.
- **Step 3:** Inspect each part one at a time, referring to the DIAGRAM for identification of each Inspection Point. Each part must be inspected for the possible presence of the conditions shown on the checklist. Compare the results with the prior Formal Inspection records if there is any question whether the Perfect Descent Climbing System condition has materially changed since the last Formal Inspection.
- **Step 4:** Determine whether each part is acceptable or not acceptable, and note pass or fail in the Pass/Fail column of the LOG.
- **Step 5:** Perform a functional test of the Perfect Descent Climbing System line extraction and retraction features. Upon completion of these functional tests, note the performance for extraction and retraction in the comments section on the Inspection Log. The extraction functional test is performed by slowly pulling the line, completely out of the Perfect Descent Climbing System housing. Note as the line is extracted from the device if there is any sticking, hesitation, or other hindrances to the smooth deployment of the line. The retraction functional test is performed by allowing the automatic retraction of the device to slowly re-reel the line back into the Perfect Descent Climbing System. The tension of the lanyard as it retracts into the Perfect Descent Climbing System should be constant, the lanyard should not snag or catch and there should not be any loud grinding noise throughout the entire retraction of the line. Note that during normal operation the internal retraction spring will produce a rubbing noise as line is extracted or retracted. This noise is more pronounced when the unit is on its back, with the brake housing facing upward. Record the results of the functional tests in the appropriate sections of the Inspection Log.
- **Step 6:** Perform a functional test of the Perfect Descent Climbing System carabiner by opening the gate and allowing it to release. Check for any hesitation in the closing of the gate. Check that the gate closes by itself. Note the results in the appropriate section of the Inspection Log.
- **Step 7:** If it has been determined that the Perfect Descent Climbing System is not acceptable for use, contact C3 Manufacturing to determine if service is required, or if the unit needs to be retired.
- **Step 8:** File the LOG for future reference.



### 13.4 FORMAL INSPECTION DIAGRAM

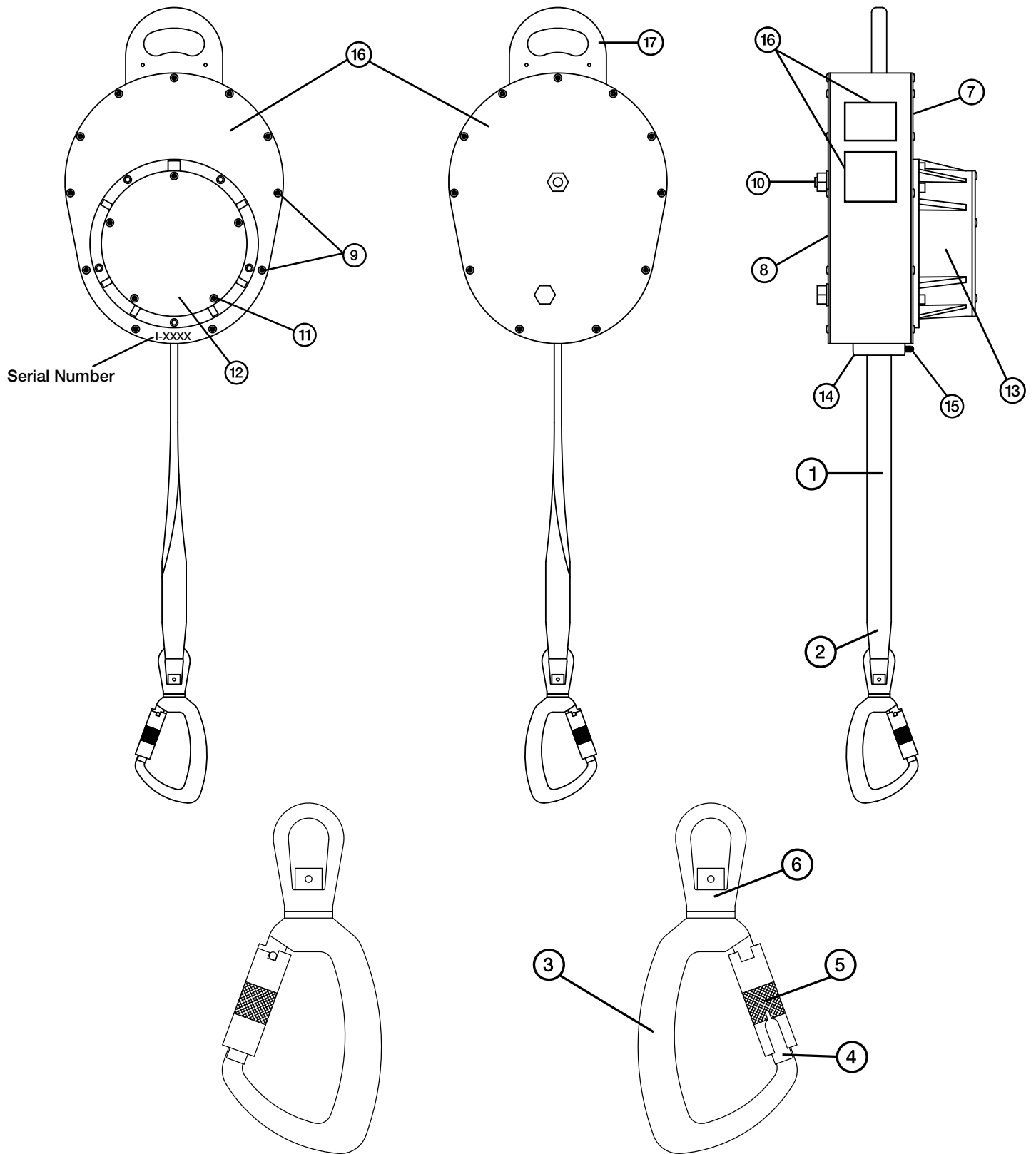

### 13.5 FORMAL INSPECTION LOG

Model Number: \_\_\_\_\_

Inspection Date: \_\_\_\_\_

Serial Number: \_\_\_\_\_

Condition of Unit: \_\_\_\_\_

Inspection Number	Description	QTY	Comments	Pass/Fail
<b>Lanyard</b>				
1	Webbing	1		
2	Stitching	n/a		
<b>Carabiner</b>				
3	Body	1		
4	Gate	1		
5	Gate Collar	1		
6	Swivel	1		
<b>Casing/Brake Housing</b>				
7	Front of Housing	1		
8	Back of Housing	1		
9	Housing Fasteners	10 or 16 per side		
10	Axle Nut	1		
11	Brake Cover Screw	6		
12	Brake Cover	1		
13	Brake Drum	1		
14	Nozzle	1		
15	Nozzle Pin	1		
16	Labels	4		
<b>Handle</b>				
17	Installation Handle	1		
<b>Function Tests</b>				
	Line Function Test	n/a		
	Carabiner Function Test	n/a		

## 13.6 FORMAL INSPECTION CHECKLIST

Part	Checklist	Overall Results / Observations
Lanyard	<ul style="list-style-type: none"> <li>❖ Cuts</li> <li>❖ Abrasion/Wear</li> <li>❖ Burns/Heat Exposure</li> <li>❖ Chemical Exposure</li> <li>❖ Faded/Sun Bleached</li> <li>❖ Missing, Broken or Frayed Stitching</li> <li>❖ Any Other Visible Issues</li> </ul>	
Carabiner	<ul style="list-style-type: none"> <li>❖ Deformed/Fractured</li> <li>❖ Rust/Corroded/Deep Pits</li> <li>❖ Missing/Loose</li> <li>❖ Heat Exposure</li> <li>❖ Chemical Exposure</li> <li>❖ Burrs/Sharp Edges</li> <li>❖ Cuts/Deep Nicks</li> <li>❖ Malfunction</li> <li>❖ Any Other Visible Issues</li> </ul>	
Casing: Front and Back	<ul style="list-style-type: none"> <li>❖ Nozzles and Pin</li> <li>❖ Damaged/Deformed</li> <li>❖ Cuts/Deep Nicks</li> <li>❖ Rust/Corroded/Deep Pits</li> <li>❖ Loose/Missing Fasteners</li> <li>❖ Heat Exposure/Burns</li> <li>❖ Chemical Exposure</li> <li>❖ Burrs/Sharp Edges</li> <li>❖ Malfunction</li> <li>❖ Any Other Visible Issues</li> </ul>	
Brake Housing	<ul style="list-style-type: none"> <li>❖ Damaged/Deformed</li> <li>❖ Cuts/Deep Nicks/Dents</li> <li>❖ Rust/Corroded/Deep Pits</li> <li>❖ Loose/Missing/Fasteners</li> <li>❖ Heat Exposure/Burns</li> <li>❖ Chemical Exposure</li> <li>❖ Burrs/Sharp Edges</li> <li>❖ Malfunction</li> <li>❖ Any Other Visible Issues</li> </ul>	
Handle	<ul style="list-style-type: none"> <li>❖ Cut/Broken</li> <li>❖ Wear Damage</li> <li>❖ Missing/Loose</li> <li>❖ Burns/Heat Exposure</li> <li>❖ Chemical Exposure</li> <li>❖ Cracked/Split</li> <li>❖ Any Other Visible Issues</li> </ul>	

## **14.0 FACTORY SERVICE**

### **14.1 FACTORY SERVICE**

- Proper maintenance and repair of the Perfect Descent Climbing System requires return of the unit to C3 Manufacturing (or to an authorized C3 Manufacturing Service Center) every two years or at any time that a competent person inspection suggests the need to remove the unit from use. The only maintenance that may be performed by the operator is cleaning, carabiner lubrication, and line replacement. All other maintenance must be performed by C3 Manufacturing or an authorized service center. The operator must never attempt to repair or alter the unit. There are no internal parts which are serviceable or replaceable by the operator, and any attempt may void the warranty.

### **14.2 OWNER REGISTRATION**

- When the Perfect Descent Climbing System is purchased, the first thing the owner and operator must do is read this Operation Manual and return the Owner Registration Card packed with the device. Each unit has a unique serial number which identifies all information associated with the unit. The serial number enables C3 Manufacturing to identify when the product was made; related engineering, manufacturing, testing and quality control records; related service records; and date it was sold and shipped to the owner or a C3 Manufacturing distributor.
- The owner registration card contains information which is vital to the maintenance of the device. It must be completely and accurately filled out and returned to C3 Manufacturing immediately after purchase.
- Be sure to enter the permanent address and telephone number of the owner. Do not enter the address and phone number of a temporary job site or temporary office. Type or print legibly in ink. This is a permanent record.

### **14.3 WHEN FACTORY SERVICE IS NECESSARY**

- The Perfect Descent Climbing System must be returned to C3 Manufacturing or an authorized factory service center upon discovery of any condition which requires removing the device from use. It is also necessary to return the unit to C3 Manufacturing or an authorized factory center after every 24 months of use. At these two year intervals it is necessary for C3 Manufacturing to perform inspection and maintenance on the internal parts of the device.
- The first factory service is required 24 months from the date of manufacture as marked on the Manufacture/Service Date Label.
- The operator can determine when the next two year factory service is required by looking at the Manufacture/Service Date Label located on the side of the unit. This label contains the date of the last factory service and the date that the next factory service is due.
- Each time the unit receives factory service a new Service Date Label is applied. The new label will show the date of the servicing.
- The Service Date Label must always be present and legible. If it is not, remove the product from use and contact C3 Manufacturing.

## 14.4 HOW TO OBTAIN FACTORY SERVICE

- When factory service for the Perfect Descent Climbing System is required for any reason, the steps below must be carefully followed:
- **Step 1:** Contact Manufacturer or Authorized Service Center  
Manufacturer: C3 Manufacturing  
Tel: 303-953-0874  
info@perfectdescent.com  
3809 Norwood Drive - Unit #4  
Littleton, CO 80125
- **Step 2:** Have the following documents available:
  - Owner's (company) name, address, phone number and fax number
  - Name of person who can be contacted to authorize repair charges, if there are any
  - Perfect Descent Climbing System serial number, type number and last factory service date
  - Brief explanation of service and known repairs to be performed (e.g., kinked line, broken carabiner, two year service, etc.)
  - Billing address if the owner already has an account with C3 Manufacturing. Otherwise, C3 Manufacturing terms are C.O.D. in the continental USA and cash in advance, including freight charges, elsewhere.
  - Return shipment address.
  - Please note that any unit sent to C3 Manufacturing or an authorized service center for service must be disassembled, inspected, reassembled and retested by C3 Manufacturing or an authorized service center in order to determine if service beyond normal service is required. Therefore, a minimum service charge must always be made.
- **Step 3:** Ship the unit, freight prepaid, to C3 Manufacturing or an authorized service center. If a unit is received with freight due it will not be accepted. ***THE OPERATIONS MANUAL AND SERVICE LOG MUST BE SECURELY ENCLOSED IN THE SHIPPING CONTAINER WITH THE UNIT.*** It is highly suggested that the original Perfect Descent Climbing System shipping container is used for shipment. Otherwise, pack the unit very securely to prevent shipping damage.
- **Step 4:** Upon receipt of the unit, C3 Manufacturing will inspect the Perfect Descent Climbing System and contact the company's representative to advise of required service and charges, if any, which are in excess of the minimum service and charges. If the service and charges are within the minimum for service, the work will be performed by C3 Manufacturing or an authorized service center and return shipped without further contact.
- **Step 5:** Upon completing the authorized service work, C3 Manufacturing or an authorized service center will record the service in the Factory Service Log in Section 14.6 of this Operation Manual and return the Operation Manual with the unit to the owner.

## 14.5 SERVICE AND INSPECTION LOGS

- It is a requirement of section 13.3 that the Perfect Descent Climbing System be formally inspected at

least every six months. C3 Manufacturing requires that the device receive factory service every two years. This two year factory service, if timely, will serve as one of the four required inspections over the course of two years. C3 Manufacturing will make the appropriate entries to both the Factory Service Log and the Formal Inspection Log at the time of factory service. It is the responsibility of the operator and the operator's management to perform timely formal inspections, log such inspections, and every two years return the unit and this Operator Instruction to C3 Manufacturing for factory service.

## **14.6 FACTORY SERVICE LOG**

- This Factory Service Log is to be filled in only by C3 Manufacturing or an authorized factory service center. At the time the unit is initially shipped from C3 Manufacturing, the date of manufacture, C3 Manufacturing part number, serial number and type number will be entered on the Log. When this manual is returned with the unit at the time of annual factory service, C3 Manufacturing personnel will enter the printed name and written initials of the service person, printed name and initials of the quality control inspector, the Service Number and the scheduled date for the next factory service. The Inspection/Service Report is a detailed report of annual factory service retained permanently by C3 Manufacturing. It is available for examination upon request.



**Note:** This form is to be filled out at the time of purchase and left attached to this Operations Manual. A duplicate registration card is provided with the unit and is to be returned to C3 Manufacturing upon purchase for unit registration. You may register the unit online at [www.perfectdescent.com/auto-belay-registration-form](http://www.perfectdescent.com/auto-belay-registration-form) in place of mailing the registration card back to C3 Manufacturing. Should ownership of the unit change, the new owner must contact C3 Manufacturing to re-register the unit.

## OWNER REGISTRATION

**IMPORTANT:** Please fill out and return this registration card at time of purchase. In addition, copy the information into the designated place in the User manual. Please print legibly in blue or black ink.

MODEL# \_\_\_\_\_ SERIAL# \_\_\_\_\_

### OWNER INFORMATION:

NAME: \_\_\_\_\_

ADDRESS: \_\_\_\_\_

PHONE: \_\_\_\_\_

BUSINESS OWNER NAME & TITLE: \_\_\_\_\_

### PURCHASED FROM:

NAME: \_\_\_\_\_

ADDRESS: \_\_\_\_\_

DATE OF PURCHASE: \_\_\_\_\_ / \_\_\_\_\_ / \_\_\_\_\_  
MONTH DAY YEAR



## WARRANTY

**Express Warranty** - C3 Manufacturing LLC warrants that the product furnished is free from mechanical defects or faulty workmanship for a period of two (2) years from date of purchase, provided it is maintained and used in accordance with C3 Manufacturing LLC instructions and/or recommendations. Replacement parts and repairs are warranted for ninety (90) days from the date of repair of the product or sale of the replacement part, whichever occurs first. This warranty applies only to the original Purchaser. C3 Manufacturing LLC shall be released from all obligations under this warranty in the event repairs or modifications are made by persons other than its own authorized service personnel or if the claim results from misuse of the product. No agent, employee or representative of C3 Manufacturing LLC may bind C3 Manufacturing LLC to any affirmation, representation or modification of the warranty concerning goods sold under this contract. C3 Manufacturing LLC makes no warranty concerning components or accessories not manufactured by C3 Manufacturing LLC but will pass on to the Purchaser all warranties of manufacturers of such components. THIS WARRANTY IS IN LIEU OF ALL OTHER WARRANTIES, EXPRESS, IMPLIED OR STATUTORY, AND IS STRICTLY LIMITED TO THE TERMS HEREOF. C3 MANUFACTURING LLC SPECIFICALLY DISCLAIMS ANY WARRANTY OF MERCHANTABILITY OR FITNESS FOR A PARTICULAR PURPOSE.

**Exclusive Remedy** - It is expressly agreed that the Purchaser's sole and exclusive remedy for breach of the above warranty, for any tortious conduct of C3 Manufacturing LLC, or for any other cause of action, shall be repair and/or replacement, at C3 Manufacturing LLC option, of any equipment or parts thereof, that after examination by C3 Manufacturing LLC are proven to be defective. Replacement equipment and/or parts will be provided at no cost to the Purchaser F.O.B. Purchaser's named place of destination. Failure of C3 Manufacturing LLC, to successfully repair any nonconforming shall not cause the remedy established hereby to fail of its essential purpose.

**Exclusion of Consequential Damages** – Purchaser specifically understands and agrees that under no circumstances will C3 Manufacturing LLC be liable to the Purchaser for economic, special, incidental, or consequential damages or losses of any kind whatsoever, including but not limited to, loss of anticipated profits and any other loss caused by reason of the non-operation of the goods. This exclusion is applicable to claims for breach of warranty, tortious conduct or any other cause of action against C3 Manufacturing LLC.

**Customer Responsibility** - These items are considered to be the responsibility of the customer and are therefore non-reimbursable under the terms of this warrant. They include : routine maintenance and inspection; normal replacement of service items; normal deterioration due to use and exposure; wearing parts such as the lanyard, carabiner nozzle and brakes; replacements required because of abuse, misuse or improper operational habits or the operator.

For additional information, please contact C3 Manufacturing LLC at 303-953-0874 or [info@perfectdescent.com](mailto:info@perfectdescent.com)





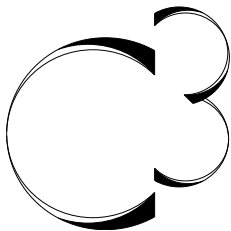

**Contact us for further information:**

3809 Norwood Drive • Unit #4 • Littleton, CO 80125 • Phone: 303-953-0874 • Fax: 303-862-8442  
Info@PerfectDescent.com • www.PerfectDescent.com

---

*Perfect Descent Climbing Systems™ is a division of C3 Manufacturing LLC*